



 重庆齿轮箱有限责任公司  
CHONGQING GEARBOX CO.,LTD

地 址: 中国重庆江津  
邮 编: 402263  
电 话: (023) 47211117 47211092 (国际贸易)  
传 真: (023) 47211011  
网 址: //www.chongchi.com  
邮 箱: cgclcc@chongchi.com  
Add: Jiangjin Chongqing China  
Post-code: 402263  
Tel: (023)47211117 47211092 (International Trading Department)  
Fax: (023)47211011  
http: //www.chongchi.com  
E-mail: cgclcc@chongchi.com



# JS 系列 中心传动磨机减速机

JS SERIES REDUCTION GEARS FOR CENTRAL DRIVEN MILLS

齿齿相依

带动未来



 重庆齿轮箱有限责任公司  
CHONGQING GEARBOX CO.,LTD



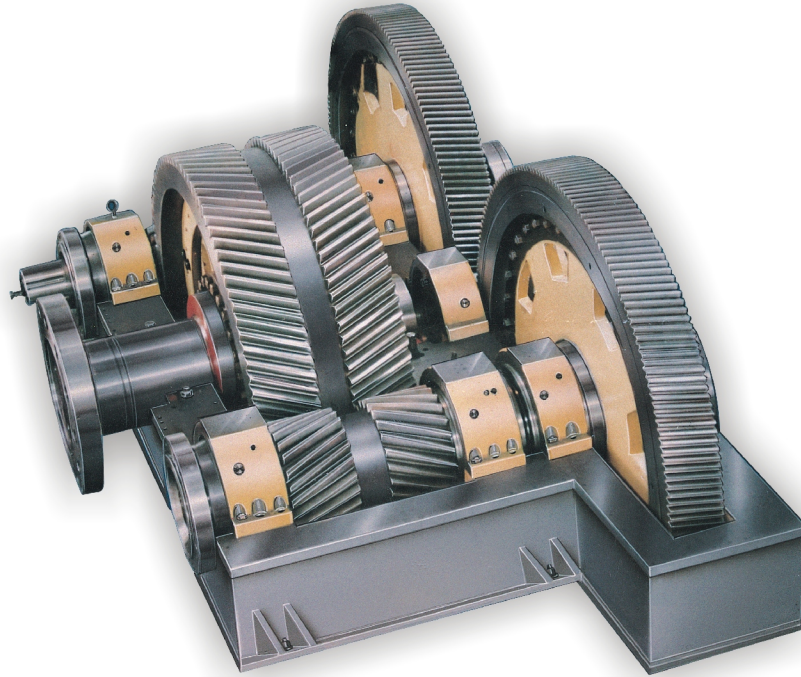
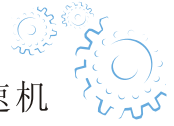

JS系列减速机是重齿公司集齿轮传动技术特别是大型高精度硬齿面，重载齿轮传动装置产品设计、制造经验，博采国外磨机减速机技术之长，开发的大功率中心传动装置。

JS系列减速机于2001年被国家建材行业标准化技术委员会审定为建材行业标准，标准号为：JC/T878.1-2001。

JS Series Reduction Gears is the main product of our company. It gathered the driving technologies, especially the rich designing and manufacturing experiences of large-scale, high precision, hardened surface and heavy-duty gear driving equipments made by our company. At the same time, it also adopted the technological advantages of the reduction Gears for mills manufactured by foreign countries. Thus a new type of large powered central driven product is developed.

In 2001, JS Series Reduction Gears was evaluated by National Construction Material Industry Standardization Technology Commission as the industrial standard with Standard No. JC/T878.1-2001



## 1、技术特点 Technical Features

JS系列中心传动磨机减速机由主减速机和慢速驱动装置，膜片联轴器，稀油站及多路温度巡显变送器等辅助系统构成。

JS Series Reduction Gears for Central Driven Mills consists of the main reduction gears,a low speed driven system,a film coupling,a lube-oil station,a multi-path temperature periodic indicator,and etc..

主减速机为平行轴渐开线圆柱齿轮传动装置。采用同轴分流和高速轮子载荷的同步传动轮系布置。结构紧凑，尺寸小、重量轻。

The Main Reduction Gears is a cylindrical gear driving device with its parallel shaft being involuted.Since a layout of power shunting and synchronous transmission gear system which can adjust the load of each gear is adopted,it possesses the features of compact structure,small size and light weight.

减速机所有传动齿轮均采用高级合金渗碳钢制造。齿轮渗碳、淬火、磨齿，具有很高的齿轮精度和负荷容量。

The High-grade alloy case-hardened steel is used for manufacturing all driving gears .The surface of each gear has been carburized,hardened and ground,so it has high precision and loading capacity.

采用多自由度的薄壁滑动轴承和偏心滑动轴承，可方便进行安装、调整，保证齿轮的啮合精度。

The thin-wall sliding bearings and eccentric sliding bearings with multidegree of freedom are used,thus its installation and adjustment can be easily done,and the accuracy of gear engagement be guaranteed.

采用焊接箱体。外形简洁、美观。

The housing of reduction gear is welded and its apper ance is simple and beautiful.

主要参数采用优化设计，零件结构标准化、尺寸系列化、组件模块化、零件通用，互换程度高。

Its main parameters have been obtained by means of optimized design.In addition,this Reduction Gears Device also bears the features of.

.Standardization in component structute,

.Seriation in size,

.Packages are all in modules,and compatability and high degree of interchangeability for all components.

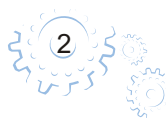

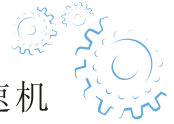

主要辅助系统慢速驱动减速机传动装置，尺寸小、重量轻、标准化程度高，可满足前驱动和后驱动等多种布置要求。

The major auxiliary system-low speed driving gear has been designed small in size, light in weight and in the way of high degree in standardization. It can meet many demands about ahead driving and astern driving.

采用膜片联轴器有效解决磨机与主机之间的不同轴度误差，并具有良好的缓冲，隔振性能。

Such as diaphragm coupling is effectively used to solve the coaxiality error between mill and main reduction gear and is provided with good buffer and vibration isolation.

独立式油站配备有两台齿轮油泵，互为备用以确保润滑系统的可靠性。完善的滑油压力，温度监测及报警系统提供了充分的设备安全保障手段，滑油加热系统可满足在高寒地带的使用要求。

The diluted oil lubricating station is equipped with 2 sets of gear pumps which can be reserved each other to ensure the reliability for lubricating system. In order to ensure the safety for equipments, good lubrication oil pressure, temperature monitoring and alarming system are used, lubrication oil heating system can meet the operation demands in the high-cold lands.

多路温度巡显变送器采用12路端面热电阻和先进的转换电路系统，由高亮度LED数码显示主减速机轴承序号和温度值。同时可向计算机控制系统提供4-20mA标准电信号以及报警系统所需的开关信号。

12 channel transveres thermal resistors and advanced change-over circuit are used for mulit-path temperature periodic indicator. Bearings' serial number of main reduction gear and temperature value are displayed by high brightness LED digital indicator. The computer' s comparator is provided with located swithching singal.

JS系列中心传动磨机减速机性能先进、可靠性高。可广泛用于建材行业的原料磨、水泥磨和冶金、矿山等行业。同时也可用于榨糖行业等。

With the features of advanced performance, high reliability, JS Series Reduction Gears for Central Driven Mill can be widely used for the raw cement mills in the fields of building materials, metallurgy industry as well as sugar in dusty, etc.

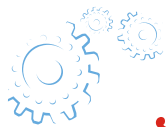

## 2、主减速机传动原理 The principle of main reduction gears

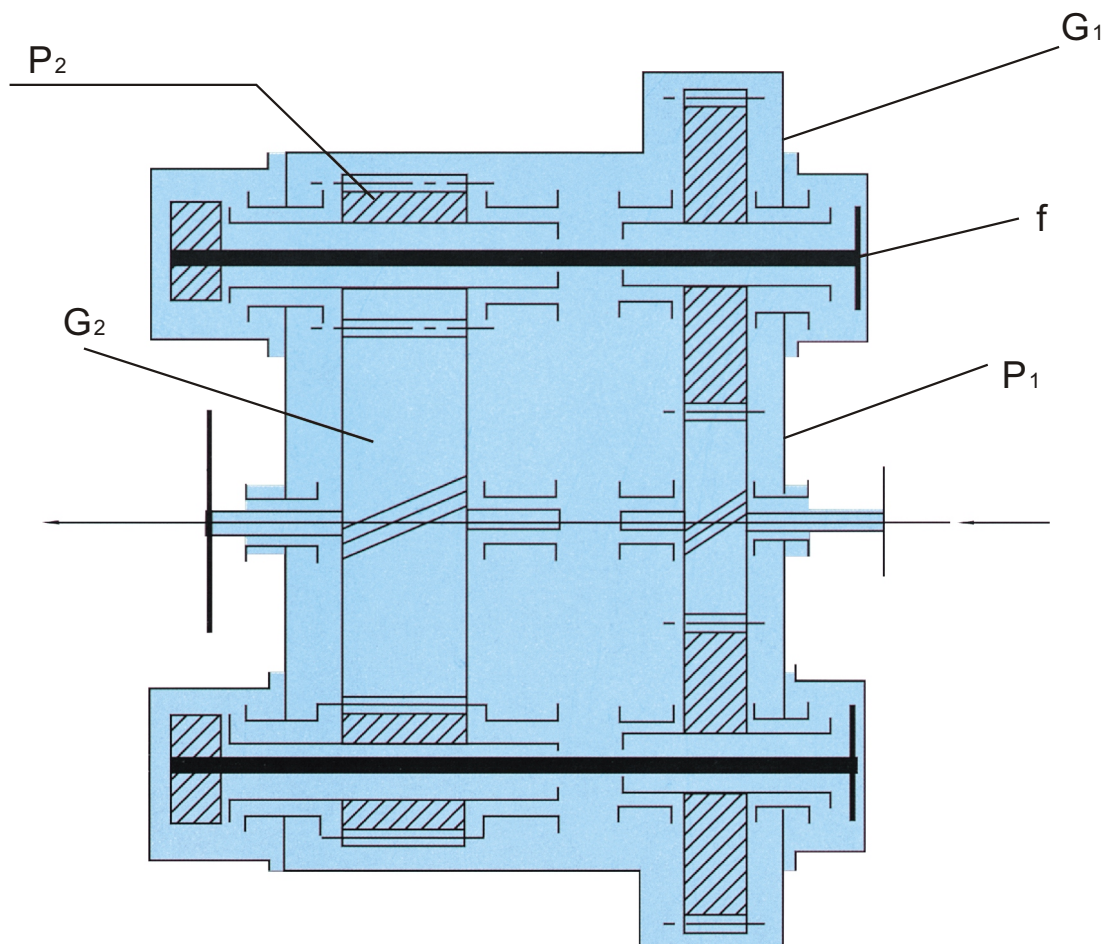

$P_1$ -一级小齿轮. 1st pinion

$P_2$ -二级小齿轮. 2nd pinion

$G_1$ -一级大齿轮. 1st gear

$G_2$ -二级大齿轮. 2nd gear

f-扭力轴. torsion shaft

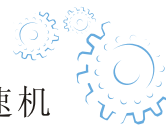

### 3、主减速机主要技术参数 Main technical parameters

型号 Size	额定功率 (kW) Rating	输入转速 (r/min) Input Speed	输出转速 (r/min) Output Speed
JS90	800	740 990	19.3 19.5
JS100	1000	595 740	17.6 19.5 18.2 18.6
JS110-A	1250	595 740	16.8 17.6 18.0 18.8 18.2
JS110-B	1400	595 740	16.8 17.6 18.0 18.8 18.2
JS120-A	1600	595 740	16.5 16.8 17.1 17.7
JS120-B	1800	595 740	16.3 16.5 16.8 17.1 17.7
JS130-A	2000	595 740	15.6 16.3 16.6 17.0 17.3
JS130-B	2250	595 740	15.6 16.3 16.6 17.0 17.3
JS130-C	2500	595 740	15.6 16.3 16.6 17.0 17.3
JS140-A	2800	595 740	15.1 16.3 16.6 15.6 16.0
JS140-B	3000	595 740	15.1 15.8 16.3 16.6 15.6
JS140-C	3150	595 740	15.1 15.8 16.3 16.6 15.6
JS150-A	3250	595 740	15.1 15.6 15.8
JS150-B	3550	595 740	15.1 15.6 15.8
JS160-A	3800	595 740	14.5 15.1 15.6
JS160-B	4000	595 740	14.5 15.1 15.6
JS160-C	4250	595 740	14.5 15.1 15.6
JS160-D	4500	595 740	14.5 15.1 15.6

※注：输出转速可按用户的不同要求进行调整。

※Note: Output speed can be adjusted according to users requests.



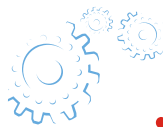

## 4、主减速机外形尺寸 Dimension

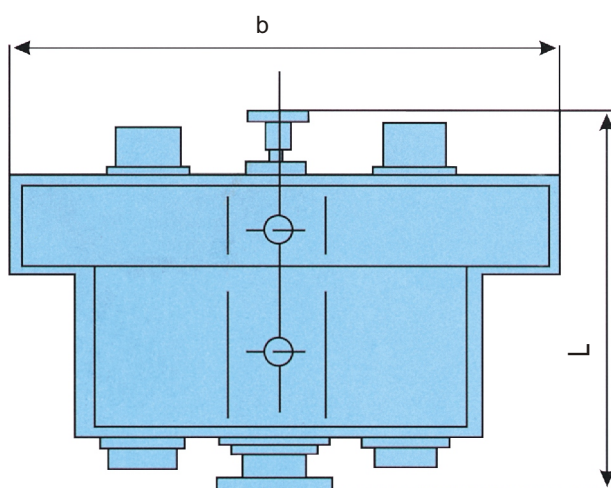
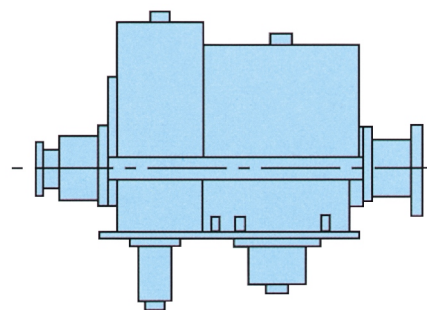
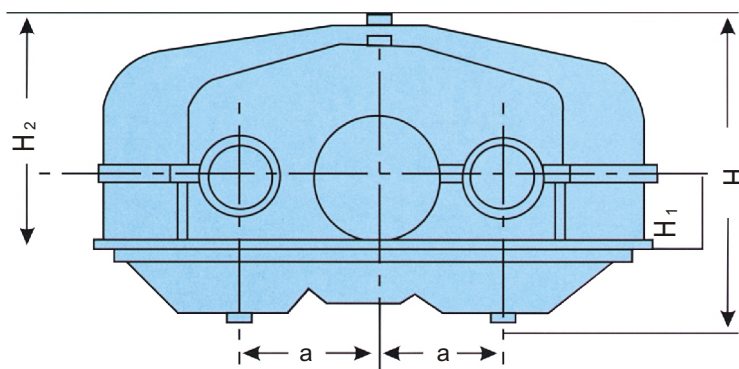

型号 Size	外形尺寸Outline Dimensions (mm)						质量 (t) Weight
	a	b	L	H	H <sub>1</sub>	H <sub>2</sub>	
JS90	900	3900	2552	1975	585	1585	21
JS100	1000	4200	2716	2225	585	1705	25
JS110-A	1100	4550	2773	2280	585	1760	31
JS110-B	1100	4550	2773	2280	585	1760	33
JS120-A	1200	5100	2960	2450	650	1860	36
JS120-B	1200	5100	2960	2450	650	1860	38
JS130-A	1300	5550	3152	2630	650	1950	45
JS130-B	1300	5550	3152	2630	650	1950	47
JS130-C	1300	5550	3152	2630	650	1950	48
JS140-A	1400	5900	3490	2850	650	2050	52
JS140-B	1400	5900	3490	2850	650	2050	56
JS140-C	1400	5900	3490	2850	650	2050	58
JS150-A	1500	6300	3540	3050	650	2160	61
JS150-B	1500	6300	3540	3050	650	2160	64
JS160-A	1600	6640	3760	3200	650	2200	76
JS160-B	1600	6640	3760	3200	650	2200	77
JS160-C	1600	6640	3760	3200	650	2200	78
JS160-D	1600	6640	3760	3200	650	2200	79

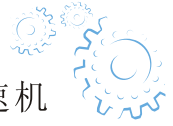

## 5、系统布置型式 System arrangement type

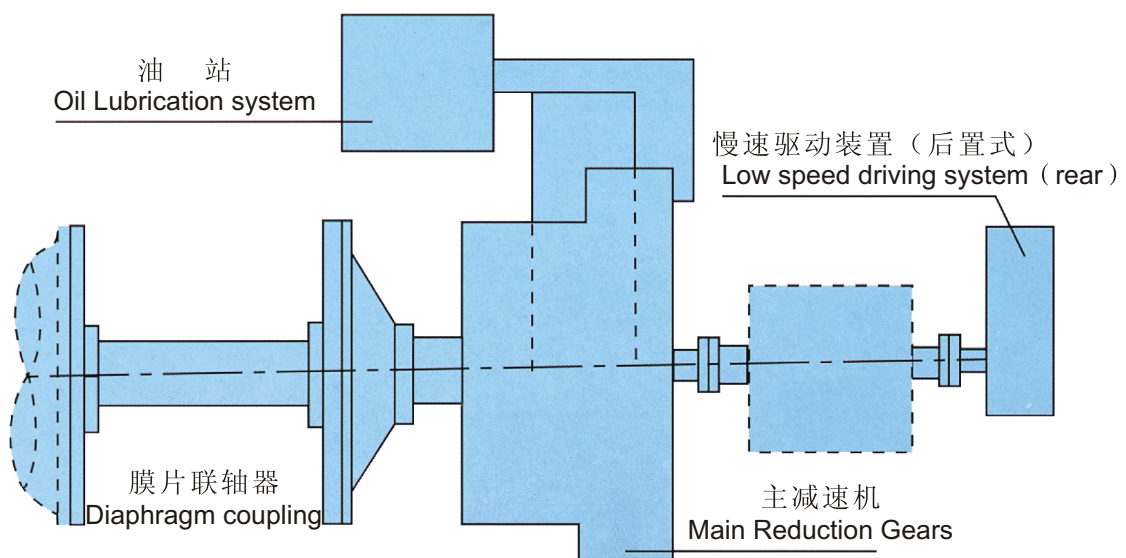
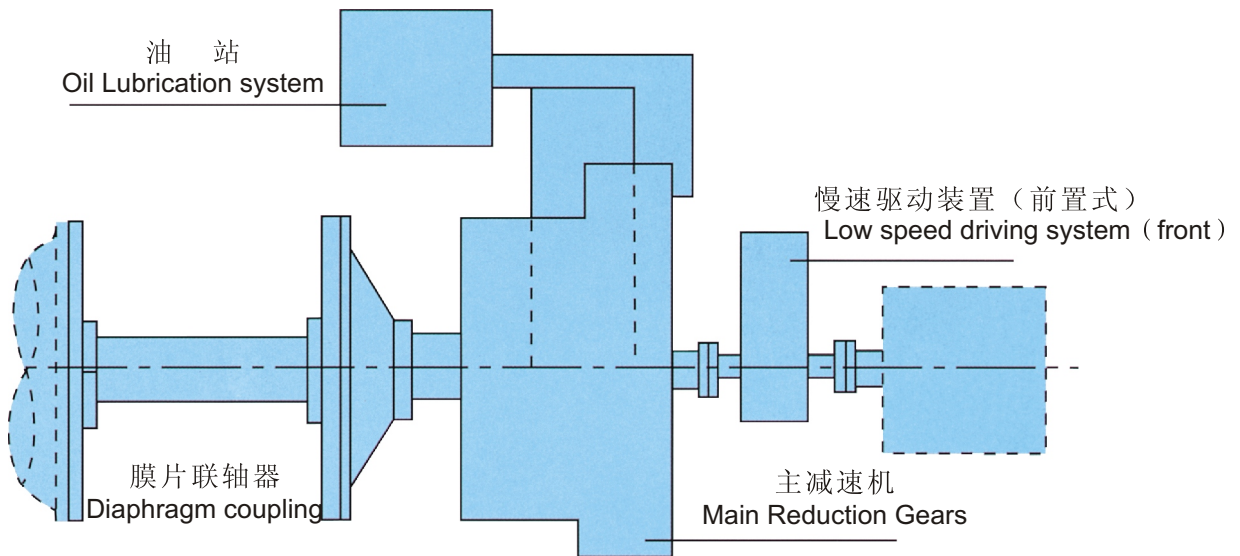

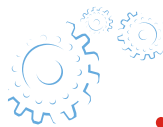

## 6、各部件质量 The weight of central driven mills

型号 Size	主减速机 Main reduction Gears	油站 Oil lubrication system	慢速驱动装置 Low speed driving system	膜片联轴器 Diaphragm coupling	总量 Overall weight
JS90	21	2.5	3.5	4.5	31.5
JS100	25	2.5	3.5	5.5	36.5
JS110-A	31	2.5	3.5	7.0	44.0
JS110-B	33	2.5	3.5	7.5	46.5
JS120-A	36	3.5	4.5	8.0	52.0
JS120-B	38	3.5	4.5	8.5	54.5
JS130-A	45	3.5	4.5	9.0	62.0
JS130-B	47	3.5	4.5	10.0	65.0
JS130-C	48	3.5	4.5	11.5	67.5
JS140-A	52	4.5	6.0	12.0	74.5
JS140-B	56	4.5	6.0	13.5	80.0
JS140-C	58	4.5	6.0	14.5	83.0
JS150-A	61	4.5	6.0	14.5	86.0
JS150-B	64	4.5	6.0	15.0	89.5
JS160-A	76	5.5	7.0	16.0	104.5
JS160-B	77	5.5	7.0	17.0	106.5
JS160-C	78	5.5	7.0	17.5	108.0
JS160-D	79	5.5	7.0	18.0	109.5

## 7、选型与定货说明 Selection and order

.根据主电机的额定功率，转速和磨机转速要求选择主减速机的型号，具体见JS系列主减速机主要技术参数。

.定货时请说明系统布置型式。

.供货范围还包括安装地脚螺栓和调整垫铁。

.根据用户的不同要求，可特殊定货。

.The reduction gear type selection based on the requests rated power, speed of main motor and speed of mill. Please refer to the main technical parameters of reduction gear.

.While ordering please state the system arrangement type.

.Mounting anchor and adjustment washer are included the supply scope.

.According to the different demands of user, we can offer special service.